

W8IO – 45HD and 45HD-065 Roof Mount Tower Assembly and Installation

19 June 2017

Please carefully follow these steps to properly assemble and install your 4.5 foot heavy duty roof mount tower.

1. Remove all items from the packages and make sure all parts are there. Refer to the parts list at the end of this manual. Model IO-45HD-065 includes the Yaesu GS-065 Thrust Bearing. Model IO-45HD does not.
2. Begin by assembling the 4 top angle brackets to the bottom of the Yaesu GS-065 thrust bearing, using the 4 bolts and 4 lock-washers supplied with the bearing. Save the other parts for future use if you wish to eventually re-purpose the thrust bearing. Tighten all bolts securely, leaving equally spaced gaps at each corner. If using the UMB-1 brackets, skip step 2.



3. Assemble 2 right legs and 2 left legs to the thrust bearing assembly as shown below, using 8 each of the 5/16"-18 x 1" bolts and locknuts. Hand-tighten the nuts at this time. The legs should have the feet attachment holes facing the floor and ceiling as shown in the next image.



4. Assemble the 4 sets of X-braces, using 4 each 5/16"-18 x 1" bolts and locknuts. Hand-tighten the hardware at this time. See the image below.



5. Lift the tower assembly to an upright position and spread the 4 tower legs apart so that they are approximately 24 inches apart at the bottom. You may need to loosen the bolts that attach the legs to the thrust bearing assembly. See the image at left below.

6. Assemble 2 sets of X-braces and lower shelves on opposite sides of the tower, using 8 each 5/16"-18 x 1" bolts and locknuts. X-braces go on the outside of the legs and the shelves go on the inside. These 2 lower shelves should have the extra holes for the rotor shelves. Push the tower legs apart before tightening the hardware. Use a wrench to tighten these 2 assemblies to the tower legs. See the image at right below.



7. Attach the remaining 2 sets of X-braces on each of the 2 open sides as shown below, using 5/16"-18 x 1" bolts and locknuts. Spread the tower legs apart until the lower holes of the X-braces line up with the holes in the tower legs. Hand-tighten the upper set of bolts in these 2 assemblies at this time. See the image below.



8. Attach the 2 remaining lower shelves to the tower assembly, using 5/16"-18 x 1" bolts and locknuts. Place each bolt through the X-brace and leg with just a couple threads showing on the other side. Place the lower shelf carefully on each bolt, then secure with a lock-washer and nut. When both shelves have been installed, tighten all hardware securely with a wrench. See the image at left below.



9. Attach the 2 rotor shelves to the lower shelf brackets with 4 each 5/16"-18 x 1" bolts and locknuts as shown above. Verify that all rotor mounting holes are 3.31" (Yaesu) or 3.0" (Hy-Gain) apart. Tighten these bolts securely. See the image at right above. These shelf brackets may fit tight.

10. Attach a foot on each leg with 3/8"-16 x 1" bolts and locknuts as shown below. Hand-tighten the hardware at this time.



11. Make sure that the tower is on a level surface. Place a level across the top of the thrust bearing, then tighten the 8 bolts that hold the top angle brackets to the 4 legs. There will be a small gap between the legs and the top brackets even when tight. Make sure that the thrust bearing AND rotor shelves are both level in 2 orthogonal directions. Securely tighten the remainder of the hardware at this time except for the bolts that hold the feet.



Installation

10. Install the rotor and mast to make sure everything fits and aligns with the thrust bearing. You can decide at this time if you wish to secure the rotor onto the rotor shelf before or after placing the tower on the roof.

11. You will need to determine how you wish to attach the tower to your roof. Bolts are recommended. The feet mounting holes are drilled to accept 3/8" bolts. These may need to be enlarged if larger bolts are used.

12. Below you can view recommended mounting procedures for a sloped roof with asphalt shingles. Other mounting methods may be used depending on your particular roof.

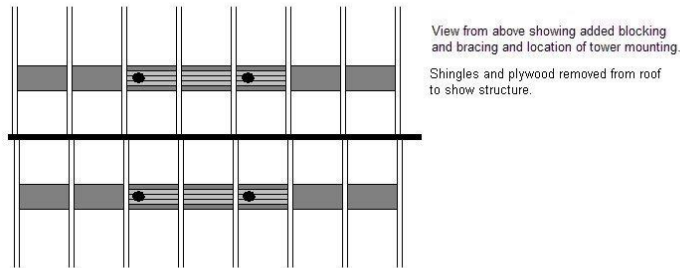
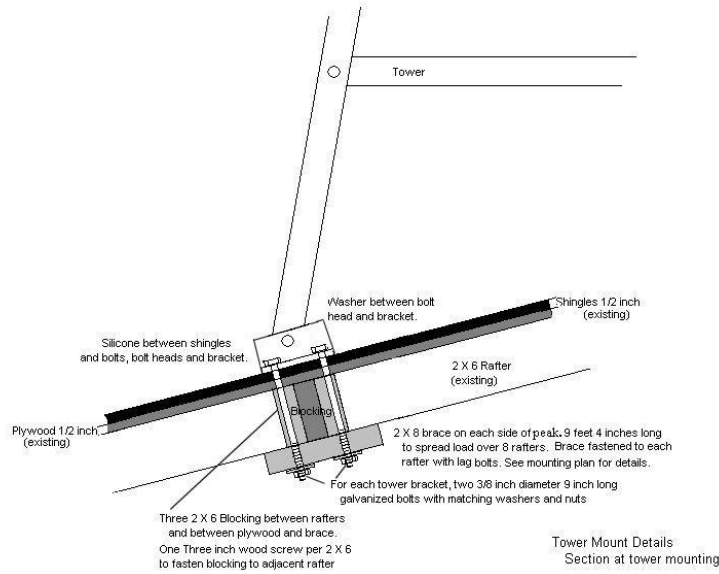

Key of roof and bracing components

- Rafter - 16 inch centers but not perfectly aligned across the ridge rafter
- Ridge Rafter at peak of roof
- Added Blocking between rafters under tower
- Added brace to spread load between rafters
2 X 8 by 9 feet 4 inches long
- Mounting points for tower
(32 inches between legs - 8 foot tower)
(27 inches between legs - 6 foot tower)
(24 inches between legs - 4 foot tower)

One 1/4 inch lag bolt fastens the brace to every rafter. Lag bolt length is 5 inches and is in the center of the brace. Washer is under the head of the bolt.

Tower mounting details Mounting plan

Parts List (per tower)

Right Leg (3/16" x 2" x 2" x 54")	2	Lower shelf bkt drilled (3/16" x 2" x 2" x 17.5")	2
Left Leg (3/16" x 2" x 2" x 54")	2	Lower shelf bkt (3/16" x 2" x 2" x 17.5")	2
Top angle bracket (3/16" x 1.2" x 2" x 5")	4	Rotor shelf – square edges (2" x 2" x 17.5")	2
Tower foot – square edges (1/4" x 2" x 2" x 6")	4	Cross braces (2" x 20")	8
5/16"-18 x 1" SS bolt	32	Yaesu GS-065 with hardware (IO-45-065 only)	1
5/16"-18 locknut SS	32	3/8"-16 x 1" SS bolt	4
3/8"-16 locknut SS	4		